

Model: **FP 800**
RCI Technologies
Universal Fuel Purifier

Nominal Flow: 15 gal/min (56.8 lts/min)
 Sump Capacity: 2.5 pt. (Approximately)
 In & Out Couplings: 1" NPT
 Top Port: 1/2" NPT
 Sensor Port *: 1/8" NPT
 Drain Valve: Comm/Brass 1/2" Valve
 Height: 16" (406.4) Strap mount
 Width: 4.5" (114.3 mm)
 Gross Weight: 11 lbs.

*Water Sensor and Heater are optional items.



APPLICATIONS
 Stationary Diesel Pumps
 and
 Equipment

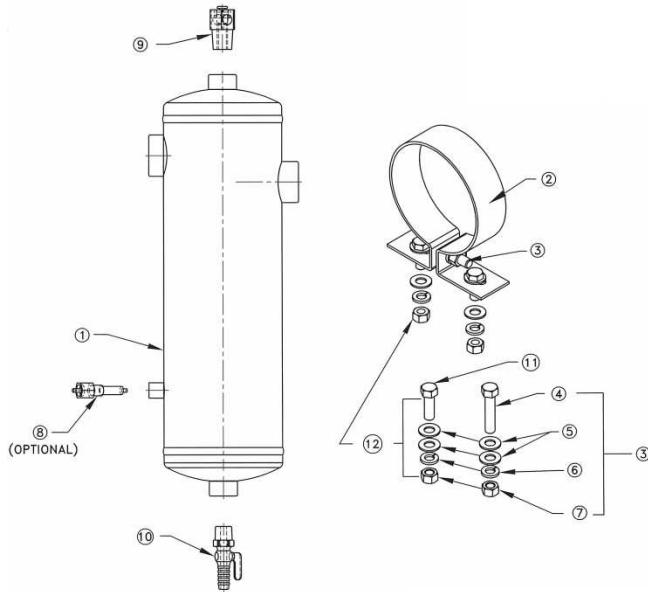

ITEM	PART NO.	DESCRIPTION	QTY
1	FP 800	FUEL PURIFIER	1
2	RC-002	BRACKET	2
3	RC-150	BOLT ASSY.	2
4	RC-151	BOLT 3/8 - 16 x 1.5" L.	2
5	RC-014	FLAT WASHER (SAE)	12
6	RC-015	LOCK WASHER	6
7	RC-107	NUT 3/8 - 16	6
8	RC-SEN-K	RCI WATER SEN. KIT (OPTIONAL)	1
9	RC-APV	AIR PURGE VALVE	1
10	RC-DVC	DRAIN VALVE COCK	1
11	RC-161	BOLT 3/8 - 16 x 1.0" L.	4
12	RC-149	BOLT ASSY.	4

